

# Part 6: Scoring in a Complete Search System



**Francesco Ricci**

Most of these slides comes from the  
course:

Information Retrieval and Web Search,  
Christopher Manning and Prabhakar  
Raghavan



# Content

- Vector space scoring
- Speeding up vector space ranking
- Putting together a complete search system

## Efficient cosine ranking

- Find the  $K$  docs in the collection “nearest” to the query  $\Rightarrow K$  largest query-doc cosines
- Efficient ranking:
  - Computing a single cosine efficiently
  - Choosing the  $K$  largest cosine values efficiently
    - Can we do this without computing all  $N$  cosines?

## Efficient cosine ranking

- What we're doing in effect: solving the  $K$ -nearest neighbor problem for a query vector
- In general, we do not know how to do this efficiently for high-dimensional spaces
- But it is solvable for short queries, and standard indexes support this well.

## Special case – unweighted queries

- No weighting on query terms
  - Assume each query term occurs only once
- Then for ranking, don't need to normalize query vector
  - Slight simplification of algorithm from Chapter 6 IIR

## Faster cosine: unweighted query

```
FASTCOSINESCORE( $q$ )
1  float  $Scores[N] = 0$ 
2  for each  $d$ 
3  do Initialize  $Length[d]$  to the length of doc  $d$ 
4  for each query term  $t$ 
5  do calculate  $w_{t,q}$  and fetch postings list for  $t$ 
6     for each pair( $d, tf_{t,d}$ ) in postings list
7     do add  $wf_{t,d}$  to  $Scores[d]$ 
8  Read the array  $Length[d]$ 
9  for each  $d$ 
10 do Divide  $Scores[d]$  by  $Length[d]$ 
11 return Top  $K$  components of  $Scores[]$ 
```

Figure 7.1 A faster algorithm for vector space scores.

## Computing the $K$ largest cosines: selection vs. sorting

- Typically we want to retrieve the top  $K$  docs (in the cosine ranking for the query)
  - not to totally order all docs in the collection
- Can we pick off docs with  $K$  highest cosines?
- Let  $J$  = number of docs with nonzero cosines
  - We seek the  $K$  best of these  $J$

## Use heap for selecting top $K$

- Binary tree in which each node's value  $>$  the values of children
- Takes  $2J$  operations to construct, then each of  $K$  "winners" read off in  $2\log J$  steps.
- For  $J=1\text{M}$ ,  $K=100$ , this is about 5% of the cost of sorting.

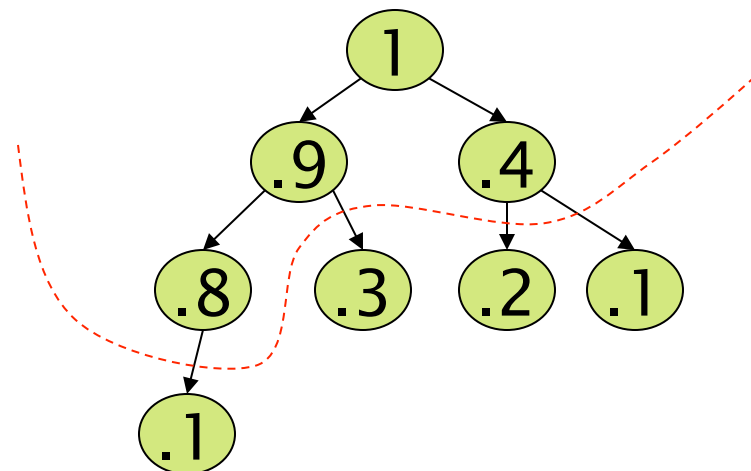

## Cosine similarity is only a proxy

- User has a task and an will formulate a query
- The system computes cosine matches docs to query
- Thus cosine is anyway a **proxy** for user happiness
- If we get a list of  $K$  docs “close” to the top  $K$  by cosine measure, should be ok
- *Remember, our final goal is to build effective and efficient systems, not to compute correctly our formulas.*

## Generic approach

- Find a set  $A$  of *contenders*, with  $K < |A| \ll N$ 
  - $A$  does not necessarily contain the top  $K$ , but has many docs from among the top  $K$
  - Return the top  $K$  docs in  $A$
- Think of  $A$  as pruning non-contenders
- The same approach is also used for other (non-cosine) scoring functions
- Will look at several schemes following this approach.

## Index elimination

- Basic algorithm FastCosineScore of Fig 7.1 only considers docs containing at least one query term – obvious !
- Take this idea further:
  - Only consider **high-idf query terms**
  - Only consider **docs** containing **many query terms.**

## High-idf query terms only

- For a query such as *"catcher in the rye"*
- Only accumulate scores from *"catcher"* and *"rye"*
- Intuition: *"in"* and *"the"* contribute little to the scores and so don't alter rank-ordering much
  - *They are present in most of the documents and their idf weight is low*
- Benefit:
  - Postings of low-idf terms have many docs – then these docs (many) get eliminated from set *A* of contenders.

## Docs containing many query terms

- Any doc with at least one query term is a candidate for the top  $K$  output list
- For multi-term queries, only compute scores for docs containing several of the query terms
  - Say, at least 3 out of 4
  - Imposes a “soft conjunction” on queries seen on web search engines (early Google)
- Easy to implement in postings traversal.

## 3 of 4 query terms

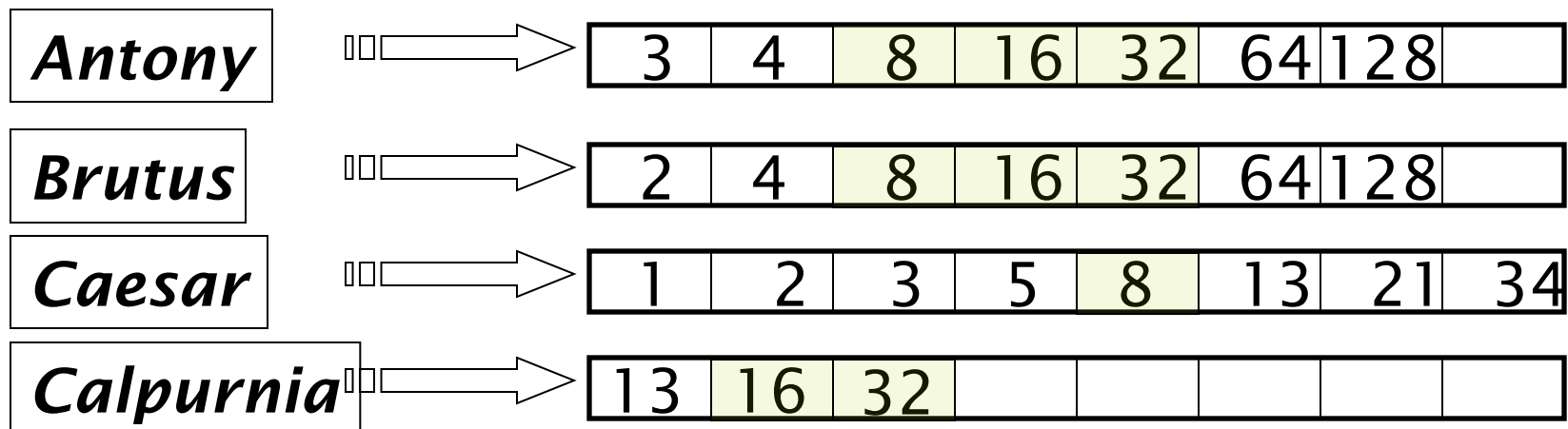

Scores only computed for docs 8, 16 and 32.

## Champion lists (documents)

- Precompute for each dictionary term  $t$ , the  $r$  docs of highest weight in  $t$ 's postings
  - Call this the champion list for  $t$
  - (aka fancy list or top docs for  $t$ )
- Note that  $r$  has to be chosen at index build time
  - Thus, it's possible that  $r < K$
- At query time, **only compute scores for docs in the champion list** of some query term
  - Pick the  $K$  top-scoring docs from amongst these.

## Exercises

- How do Champion Lists relate to Index Elimination? (i.e., eliminating query terms with low idf – compute the score only if a certain number of query terms appear in the document)
- Can they be used together?
- How can Champion Lists be implemented in an inverted index?
  - Note that the champion list has nothing to do with small docIDs.

## Static quality scores

- We want top-ranking documents to be both *relevant* and *authoritative*
- *Relevance* is being modeled by cosine scores
- **Authority** is typically a query-independent property of a document
- *Examples of authority signals*
  - Wikipedia among websites
  - Articles in certain newspapers
  - A paper with many citations
  - Many diggs, Y!buzzes or del.icio.us marks
  - Pagerank

## Modeling authority

- Assign to each document a *query-independent quality score* in  $[0,1]$  to each document  $d$ 
  - Denote this by  $g(d)$
- Thus, a quantity like the number of citations is scaled into  $[0,1]$ 
  - Exercise: suggest a formula for this.

## Net score

- Consider a simple total score combining cosine relevance and authority
- $\text{net-score}(q,d) = g(d) + \text{cosine}(q,d)$ 
  - Can use some other linear combination than an equal weighting
  - Indeed, any function of the two “signals” of user happiness – more later
- Now we seek the top  $K$  docs by net-score.

## Top $K$ by net score – fast methods

- First idea: Order all postings by  $g(d)$
- Key: this is a common ordering for all postings
- Thus, can concurrently traverse query terms' postings for
  - Postings intersection
  - Cosine score computation
- Exercise: write pseudocode for cosine score computation if postings are ordered by  $g(d)$

## Why order postings by $g(d)$ ?

- Under  $g(d)$ -ordering, top-scoring docs likely to appear early in postings traversal
- In time-bound applications (say, we have to return whatever search results we can in 50 ms), this allows us to stop postings traversal early
  - Shortcut of computing scores for all docs in postings.

## Champion lists in $g(d)$ -ordering

- Can combine champion lists with  $g(d)$ -ordering
- Maintain for each term a champion list of the  $r$  docs with highest  $g(d) + \text{tf-idf}_{td}$
- Seek top- $K$  results from only the docs in these champion lists.

## High and low lists

- For each term, we maintain two postings lists called *high* and *low*
  - Think of *high* as the champion list
- When traversing postings on a query, only traverse *high* lists first
  - If we get more than  $K$  docs, select the top  $K$  and stop
  - Else proceed to get docs from the *low* lists
- Can be used even for simple cosine scores, without global quality  $g(d)$
- A means for segmenting index into two tiers.

## Impact-ordered postings

- We only want to compute scores for docs for which  $wf_{t,d}$  is high enough
- We sort each postings list by  $wf_{t,d}$
- Now: not all postings in a common order!
- How do we compute scores in order to pick off top  $K$ ?
  - Two ideas follow

# 1. Early termination

- When traversing  $t$ 's postings, stop early after either
  - a fixed number of  $r$  docs
  - $wf_{t,d}$  drops below some threshold
- Take the union of the resulting sets of docs
  - Documents from the postings of each query term
- Compute only the scores for docs in this union.

## 2. idf-ordered terms

- When considering the postings of **query** terms
- Look at them in order of decreasing idf (*if there are many*)
  - High idf terms likely to contribute most to score
- As we update score contribution from each query term
  - Stop if doc scores relatively unchanged
  - This will happen for **popular** query terms (low idf)
- Can apply to cosine or some other net scores.

## Parametric and zone indexes

- Thus far, a doc has been a sequence of terms
- In fact documents have multiple parts, some with special semantics:
  - Author
  - Title
  - Date of publication
  - Language
  - Format
  - etc.
- These constitute the metadata about a document.

## Fields

- We sometimes wish to search by these metadata
  - E.g., find docs authored by William Shakespeare in the year 1601, containing *alas poor Yorick*
- Year = 1601 is an example of a field
- Also, author last name = shakespeare, etc
- Field index: postings for each field value
  - Sometimes build range trees (e.g., for dates)
- Field query typically treated as conjunction
  - (doc *must* be authored by shakespeare)

# Zone

- A zone is a region of the doc that can contain an arbitrary amount of text e.g.,
  - Title
  - Abstract
  - References ...
- Build inverted indexes on zones as well to permit querying
- E.g., “find docs with *merchant* in the title zone and matching the query *gentle rain*”

## Example zone indexes

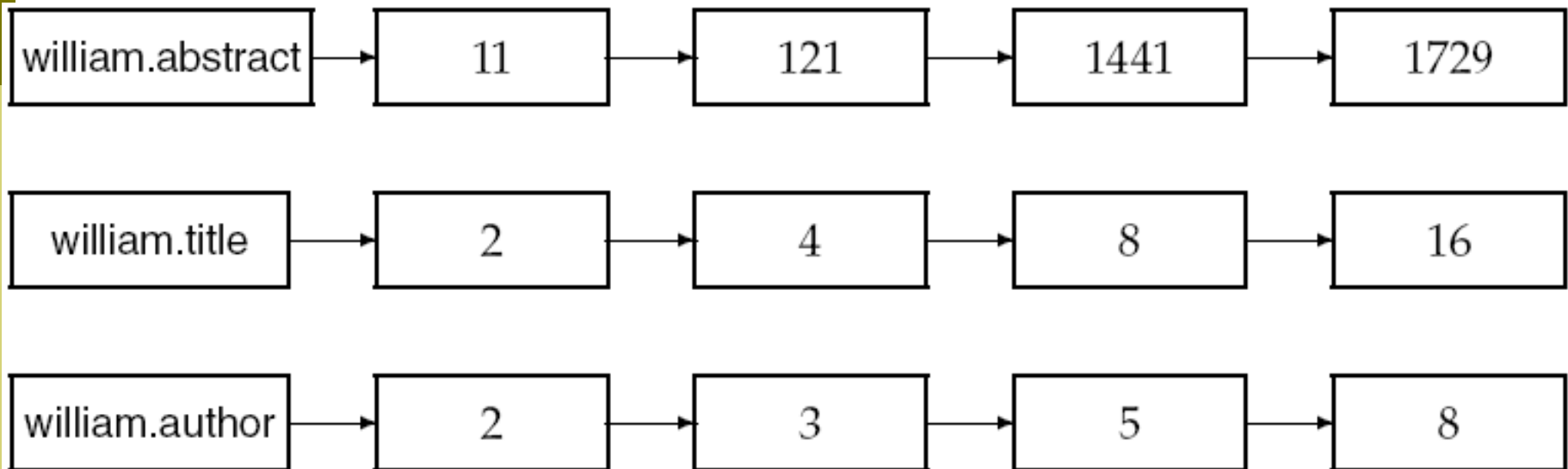

Encode zones in dictionary vs. postings.

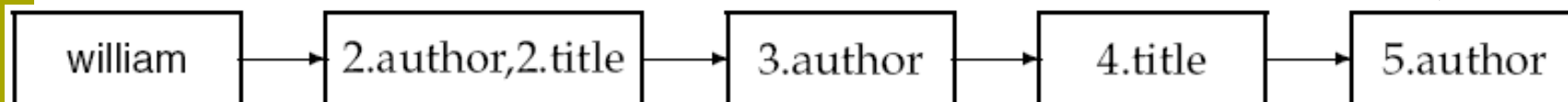

## Tiered indexes

- Break **postings** (*not documents*) up into a hierarchy of lists
  - Most important
  - ...
  - Least important
- Can be done by  $g(d)$  or another measure
- Inverted index thus broken up into tiers of decreasing importance
- At query time use top tier unless it fails to yield  $K$  docs
  - If so drop to lower tiers.

# Example tiered index

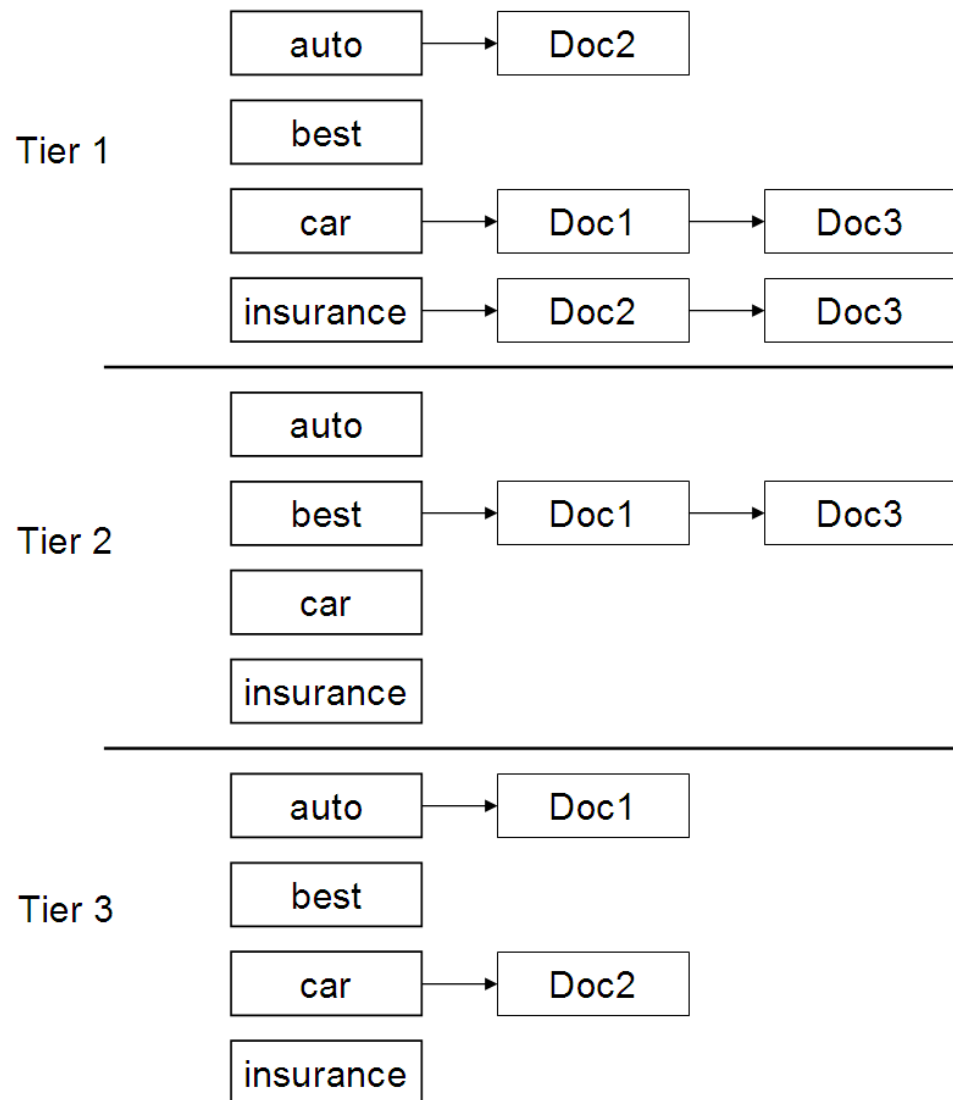

## Query term proximity

- Free text queries: just a set of terms typed into the query box – common on the web
- Users prefer docs in which query terms occur within close proximity of each other
- Let  $w$  be the smallest window in a doc containing all query terms, e.g.,
- For the query "*strained mercy*" the smallest window in the doc "*The quality of mercy is not strained*" is 4 (words)
- Would like scoring function to take this into account – how?

## Query parsers

- Free text query from user may in fact spawn one or more queries to the indexes, e.g. query *rising interest rates*
  - Run the query as a **phrase query**
  - If  $<K$  docs contain the phrase *rising interest rates*, run the two phrase queries *rising interest* and *interest rates*
  - If we still have  $<K$  docs, run the **vector space query** *rising interest rates*
  - Rank matching docs by vector space scoring
- This sequence is issued by a query parser.

## Aggregate scores

- We've seen that score functions can combine cosine, static quality, proximity, etc.
- How do we know the best combination?
- Some applications – expert-tuned
- Increasingly common: machine-learned
  - See a forthcoming lecture.

# Putting it all together

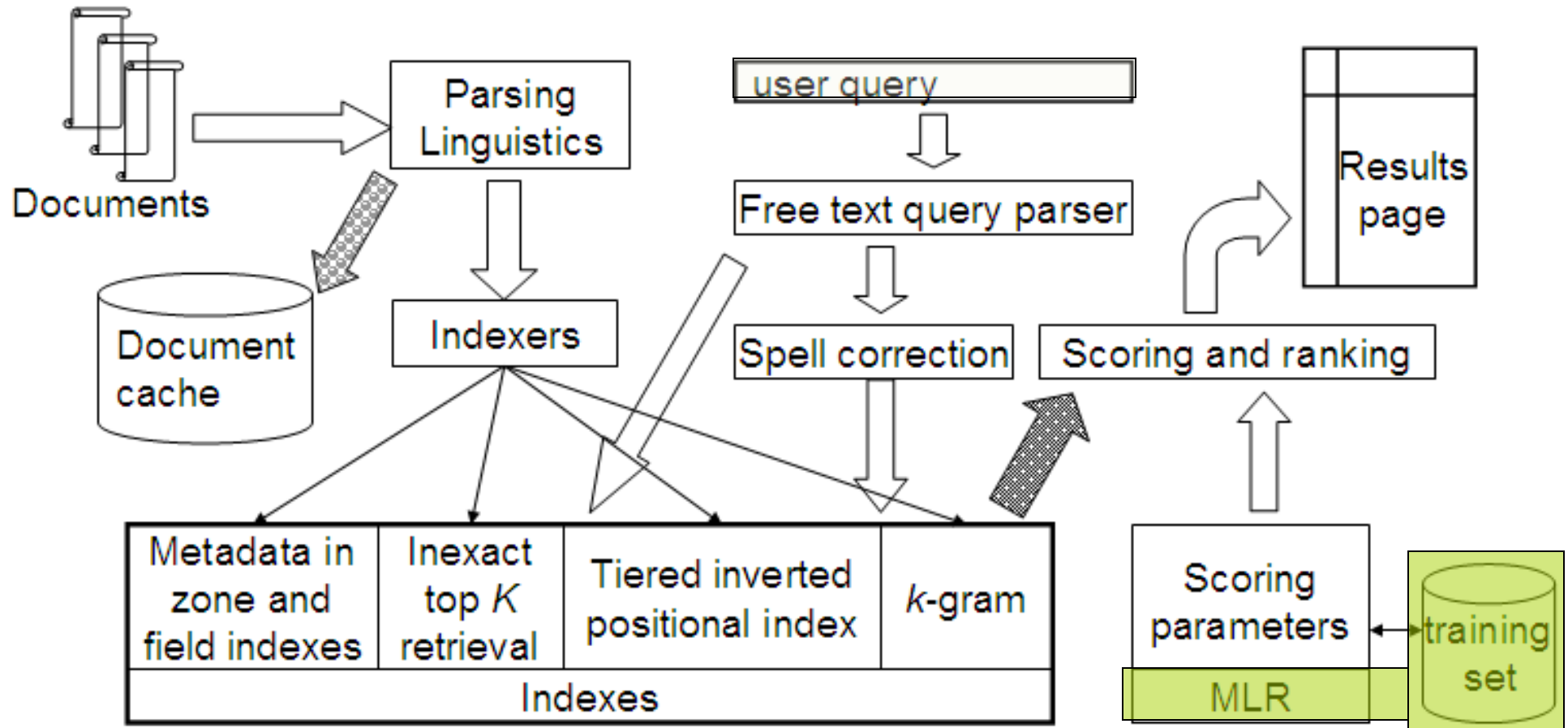



# Reading Material

- ▣ Sections: 7.1, 7.2