

Data Structures and Algorithms

Chapter 5

Dynamic Data Structures and Abstract Data Types

Werner Nutt

Acknowledgments

- The course follows the book “Introduction to Algorithms”, by **Cormen, Leiserson, Rivest and Stein**, MIT Press [CLRST]. Many examples displayed in these slides are taken from their book.
- These slides are based on those developed by Michael Böhlen for this course.

(See <http://www.inf.unibz.it/dis/teaching/DSA/>)

- The slides also include a number of additions made by Roberto Sebastiani and Kurt Ranalter when they taught later editions of this course

(See http://disi.unitn.it/~rseba/DIDATTICA/dsa2011_BZ//)

DSA, Chapter 5: Overview

- Dynamic Data Structures
 - Records, Pointers
 - Lists
- Abstract Data Types
 - Stack, Queue
 - Ordered Lists
 - Priority Queue

DSA, Chapter 5: Overview

- **Dynamic Data Structures**
 - Records, Pointers
 - Lists
- Abstract Data Types
 - Stack, Queue
 - Ordered Lists
 - Priority Queue

DSA, Chapter 5: Overview

- **Dynamic Data Structures**
 - **Records, Pointers**
 - Lists
- **Abstract Data Types**
 - Stack, Queue
 - Ordered Lists
 - Priority Queue

Records

- Records are used to group a number of (different) fields
- A *person* record may group
 - name,*
 - age,*
 - city,*
 - nationality,*
 - ssn*
- Grouping of fields is a basic and often used technique
- It is available in all programming languages

Records in Java

In Java a *class* is used to group fields:

```
class Rec {
    int a; int b;
};

public class Dummy {

    static Rec r;

    public static void main(String args[]) {
        r = new Rec();
        r.a = 15; r.b = 8;
        System.out.print("Adding a and b yields ");
        System.out.println(r.a + r.b);
    }
}
```

Records in C

In C a *struct* is used to group fields:

```
struct rec {
    int a;
    int b;
};

struct rec r;

int main() {
    r.a = 5; r.b = 8;
    printf("The sum of a and b is %d\n", r.a + r.b);
}

// gcc -o dummy dummy.c ; ./dummy
```

Recursive Data Structures

The counterpart of recursive functions are recursively defined data structures

- Example: list of integers

$$\text{list} = \left\{ \begin{array}{l} \text{integer} \\ \text{integer, list} \end{array} \right\}$$

- In Java:

```
class List{  
    int value;  
    List tail;  
};
```

- In C:

```
struct list{  
    int value;  
    struct list *tail;  
};
```

Recursive Data Structures/2

The **storage space** of recursive data structures is not known in advance.

- It is determined by the number of elements that will be stored in the list
- This is only known during **runtime** (program execution)
- The list can **grow** and **shrink during** program execution

Recursive Data Structures/3

There must be mechanisms

- to **constrain** the initial **storage space** of recursive data structures (it is potentially infinite)
- to **grow and shrink** the storage space of a recursive data structures during program execution

Pointers

- A common technique is to **allocate** the storage space (memory) **dynamically**
- That means the storage space is allocated when the **program executes**
- The compiler only reserves space for an **address** to these dynamic parts
- These addresses are called **pointers**

Pointers/2

- integer **i**
- pointer **p** to an integer (**55**)
- record **r** with integer components **a** (**17**) and **b** (**24**)
- pointer **s** that points to **r**

Address	Variable	Memory
1af782	i	23
1af783	p	1af789
1af784	r	17
1af785		24
1af786	s	1af784
1af787		
1af788		
1af789		55
1af78a		

Pointers in C

1. To follow (chase, **dereference**) a pointer variable, we write `*p`

```
*p = 12
```

2. To get the **address** of a variable `i`, we write `&i`

```
p = &i
```

3. To **allocate memory**, we use `malloc(sizeof(Type))`, which returns an address in the memory heap

```
p = malloc(sizeof(int))
```

4. To **free storage space** pointed to by a pointer `p` we use `free`

```
free(p)
```

Pointers in C/2

- To declare a pointer to type T we write T*
 - `int* p`
- Note that * is used for two purposes:
 - **Declaring** a pointer variable
 - `int* p`
 - **Following** a pointer
 - `*p = 15`
- In other languages these are syntactically different

Pointers in C/3

	Address	Variable	Memory
• <code>int i</code> <code>i = 23</code>	1af782	<code>i</code>	23
• <code>int* p</code> <code>p = malloc(sizeof(int))</code> <code>*p = 55</code>	1af783	<code>p</code>	1af789
	1af784	<code>r</code>	17
	1af785		24
• <code>struct rec r</code> <code>r.a = 17</code> <code>r.b = 24</code>	1af786	<code>s</code>	1af784
	1af787		
	1af788		
• <code>struct rec* s;</code> <code>s = &r</code>	1af789		55
	1af78a		

Pointers in C/4

Alternative notation:

Address	Variable	Memory
1af782	i	23
1af783	p	1af789
1af784	r	17
1af785		24
1af786	s	1af784
1af787		
1af788		
1af789		55
1af78a		

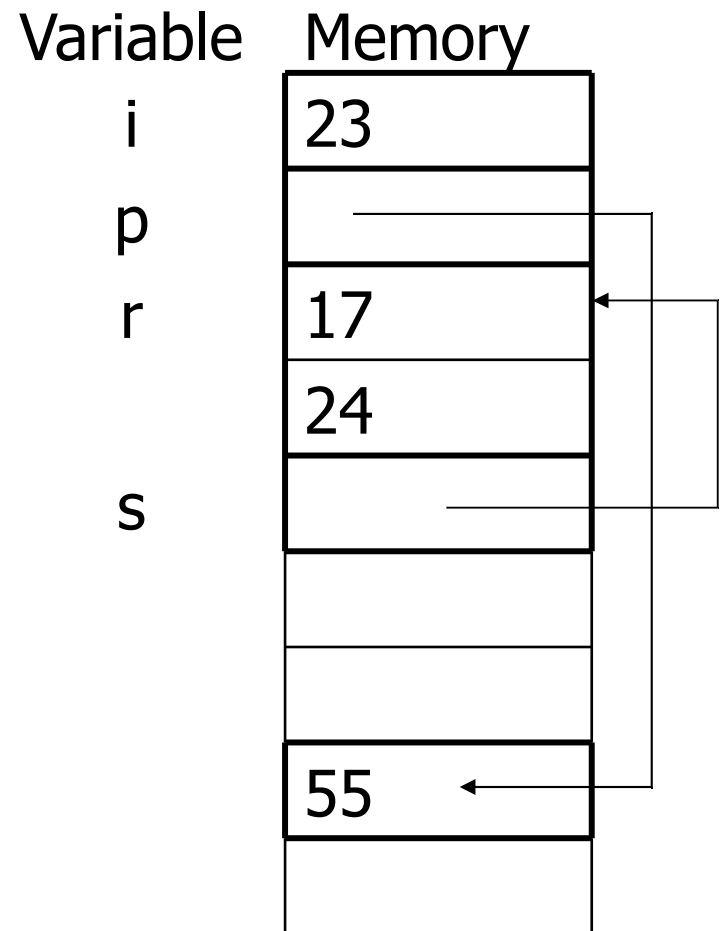

Pointers/3

- Pointers are only **one** mechanism to implement **recursive data structures**
- Programmers need not be aware of their existence
The **storage space** can be managed **automatically**
- In **C** the storage space has to be managed **explicitly**
- In **Java**
 - an **object** is implemented as a **pointer**
 - **creation** of objects (`new`)
automatically allocates **storage** space.
 - **accessing** an object will **automatically** follow the pointer
 - **deallocation** is done **automatically** (garbage collection)

DSA, Chapter 5: Overview

- Dynamic Data Structures
 - Records, Pointers
 - Lists
- Abstract Data Types
 - Stack, Queue
 - Ordered Lists
 - Priority Queue

Lists

- A list of integers:

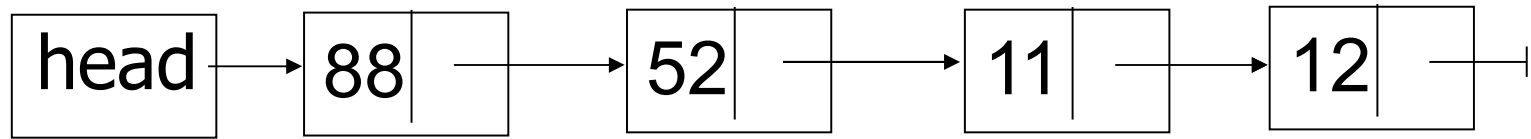

- Corresponding declaration in Java:

```
class Node {  
    int val;  
    Node next;  
}  
  
class List {  
    Node head;  
}
```

- Accessing a field: `p.a`

Lists/3

- Populating the list with integers (Java):

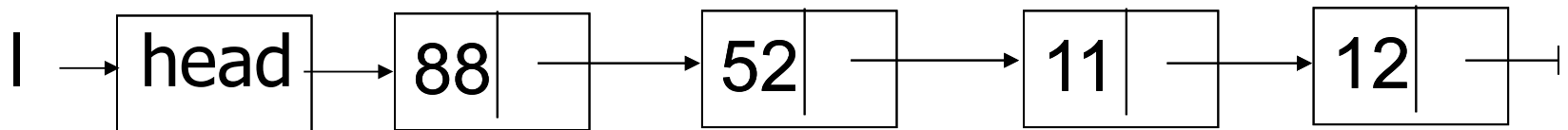

```
l = new List();  
l.head = new Node();  
l.head.val = 88;  
l.head.next = new Node();  
  
p = l.head.next;  
p.val = 52;  
p.next = new Node();
```

```
p = p.next;  
p.val = 11;  
p.next = new Node();  
  
p = p.next;  
p.val = 12;  
p.next = null;
```

List Traversal

- Print all elements of a list (Java):

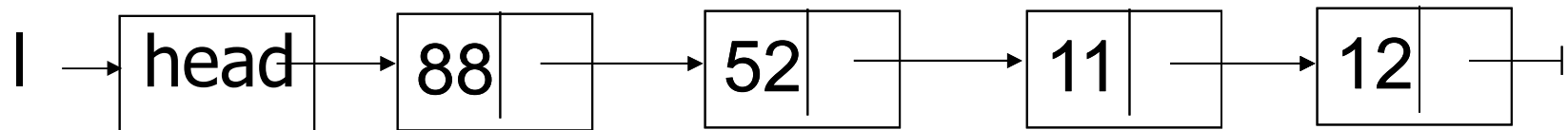

```
void print() {  
    Node node = root;  
    while (node != null) {  
        System.out.printf("%d,", node.val);  
        node = node.next;  
    }  
    System.out.printf("\n");  
}
```

List Traversal: Recursive Version

- Print all elements of a list (Java):

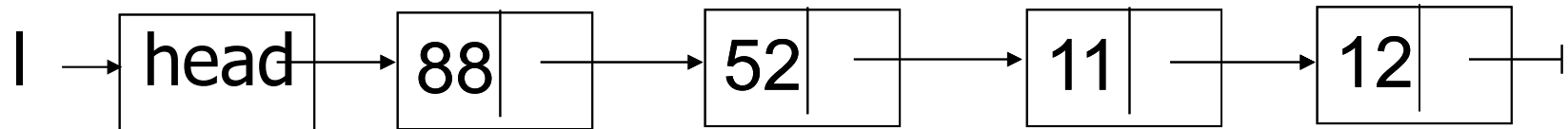

```
void printRec () {  
    printRec (head) ;  
}  
  
void printRec (Node node) {  
    if (node == null) {  
        System.out.printf ("\n") ;  
    } else {  
        System.out.printf ("%d, ", node.val) ;  
        printRec (node.next) ;  
    }  
}
```

Length of a List: Iteration

- Count the number of nodes in the list (Java):

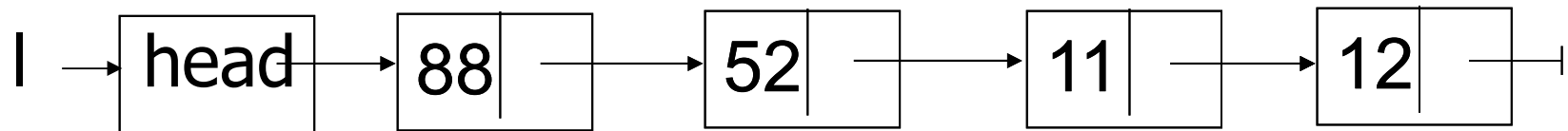

```
public int length() {  
    Node node = head;  
    int length = 0;  
    while (node != null) {  
        length++;  
        node = node.next;  
    }  
    return length;  
}
```

Length of a List: Recursion

- Count the number of nodes in the list (Java):

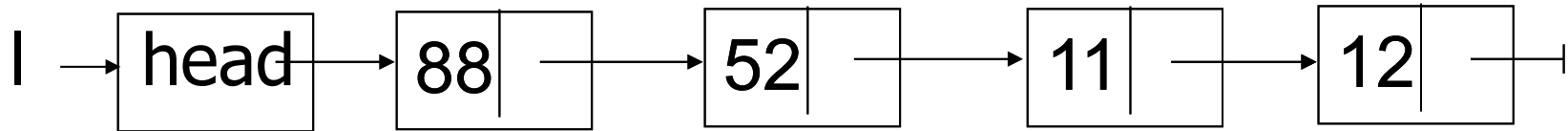

```
public int length() {  
    return length(root);  
}  
  
int length(Node node) {  
    if (node == null) {  
        return 0;  
    } else {  
        return 1 + length(node.next);  
    }  
}
```

Length of a List: Tail Recursion

- Count the number of nodes in the list (Java):

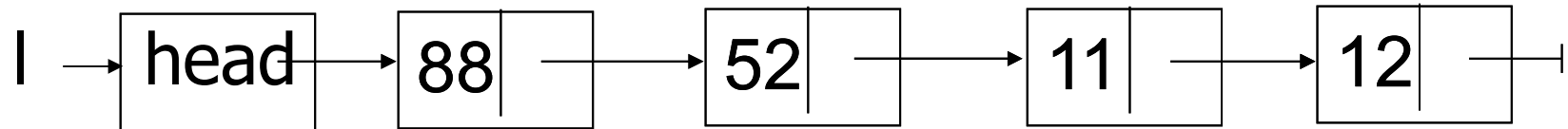

using an accumulator argument (`lengthSoFar`)

```
public int length() {
    return length(root, 0);
}

int length(Node node, int lengthSoFar) {
    if (node == null) {
        return lengthSoFar;
    } else {
        return length(node.next, lengthSoFar+1);
    }
}
```

Get Number at Position i

- Recursive version

```
public int get(int i) {
    // get value at position i
    // suppose that i >= 0, and head has position 0
    Node p = head;
    while (p != null && i > 0) {
        p = p.next;
        i--;
    }
    if (p == null) {
        throw new RuntimeException("Pos not in list");
    } else {
        return p.val;
    }
}
```

Get Number at Position $i/2$

- Iterative version

```
public int get(int i) {
    // get value at position i
    // suppose that i >= 0, and head has position 0
    Node p = head;
    while (p != null && i > 0) {
        p = p.next;
        i--;
    }
    if (p == null) {
        throw new RuntimeException("Pos not in list");
    } else {
        return p.val;
    }
}
```

List Insertion at Head Position

- Add a node with a give value (e.g., 43) as the head:

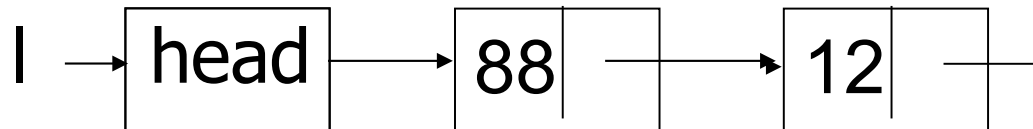

```
public void addAsHead(int v) {  
    Node node = new Node(v);  
    node.next = head;  
    head = node;  
}
```

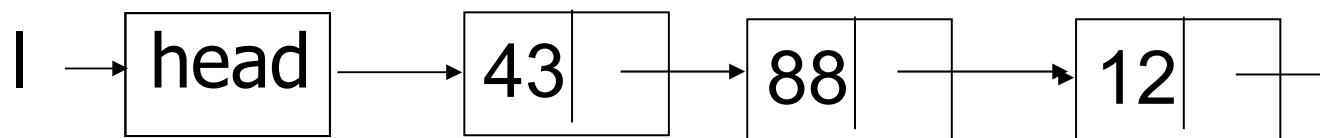

List Insertion at Tail Position

- Insert 43 at end (Java):

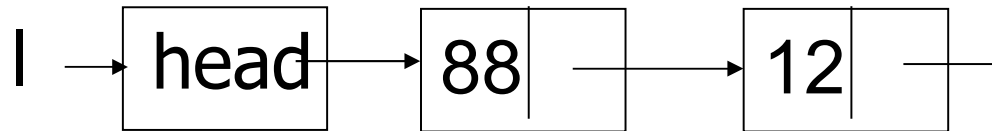

```
public void addAsTail(int v) {  
    if (head == null) {  
        head = new Node(v);  
    } else {  
        Node p = head;  
        while (p.next != null) {  
            p = p.next;  
        }  
        p.next = new Node(v);  
    }  
}
```

Insert Number at Position i

- recursive version

```
public void insertNumberAtRec(int v, int i) {
    if (i == 0) {
        Node n = new Node(v);
        n.next = head;
        head = n;
    } else {
        insertNumberAfterRec(v, head, i);
    }
}
```

Insert Number at Position $i/2$

- recursive version, continued

```
void insertNumberAfterRec(int v, Node n, int i) {
    if (n == null) {
        throw new RuntimeException("Pos not in list");
    } else if (i == 0) {
        Node newNode = new Node(v);
        newNode.next = n.next;
        n.next = newNode;
    } else {
        insertNumberAfterRec(v, n.next, i-1);
    }
}
```

Copying a list

Returns a list with new nodes that is a copy of the original list

```
public List copy() {
    List copy = new List();
    return copy(head, copy);
}

List copy(Node node, List copy) {
    if (node == null) {
        return copy;
    } else {
        List copyNext = copy(node.next, copy);
        copyNext.addAsHead(node.val);
        return copyNext;
    }
}
```

Node Removal (Iterative)

- Remove (first) node with value v from a non-empty list:

```
void removeFirst(int v) {
    if (head == null) {
        return;
    } else if (head.val == v) {
        head = head.next;
    } else {
        Node p = head;
        while (p.next != null && p.next.val != v) {
            p = p.next;
        }
        if (p.next != null) {
            p.next = p.next.next;
        }
    }
}
```

Lists

Cost of operations:

- insert at beginning: $O(1)$
- insert at end: $O(n)$
- check isEmpty: $O(1)$
- delete first node of list: $O(1)$
- search: $O(n)$
- delete: $O(n)$
- print: $O(n)$

Suggested Exercises

- Implement a linked list with the following functionalities: isEmpty, insertFirst, insertLast, search, deleteFirst, delete, print
- As before, with a recursive version of: insertLast, search, delete, print
 - are recursive versions simpler?
- Implement an efficient version of print which prints the list in reverse order

Variants of Linked Lists

- Linked lists with explicit head/tail
- Doubly linked lists

List with Explicit Head/Tail

- Instead of a single *head* we can have a *head* and *tail*:

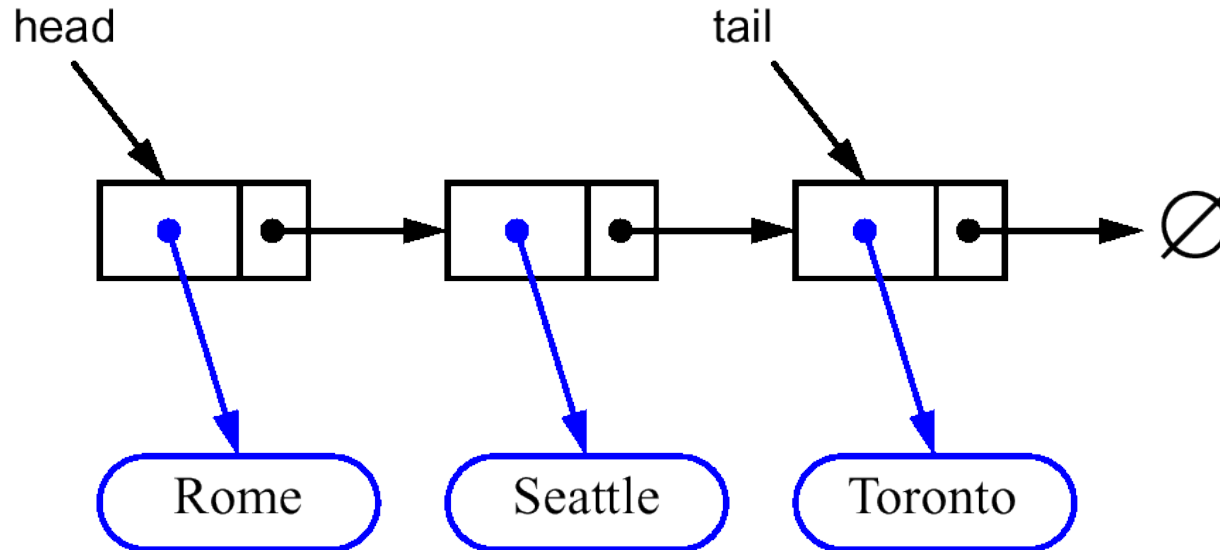

Doubly Linked Lists

- To be able to quickly navigate back and forth in a list we use **doubly linked lists**

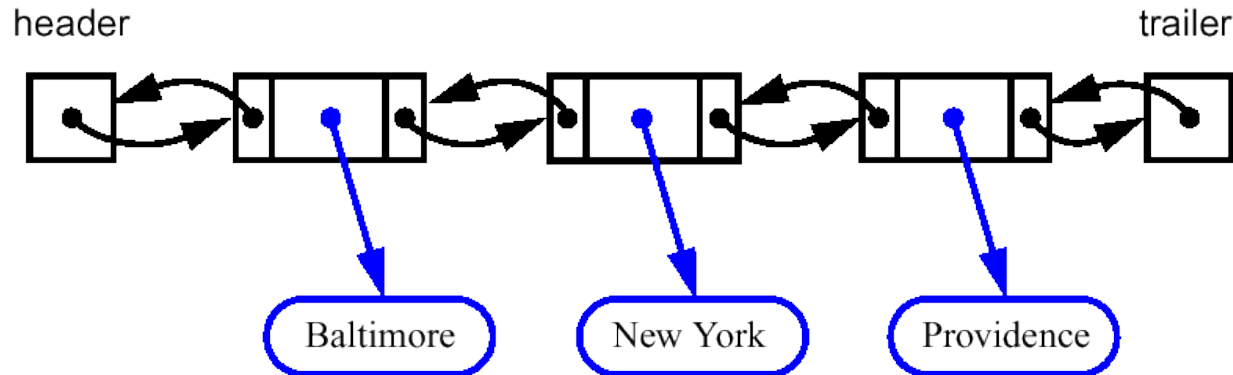

- A node of a doubly linked list has a **next** and a **prev** link

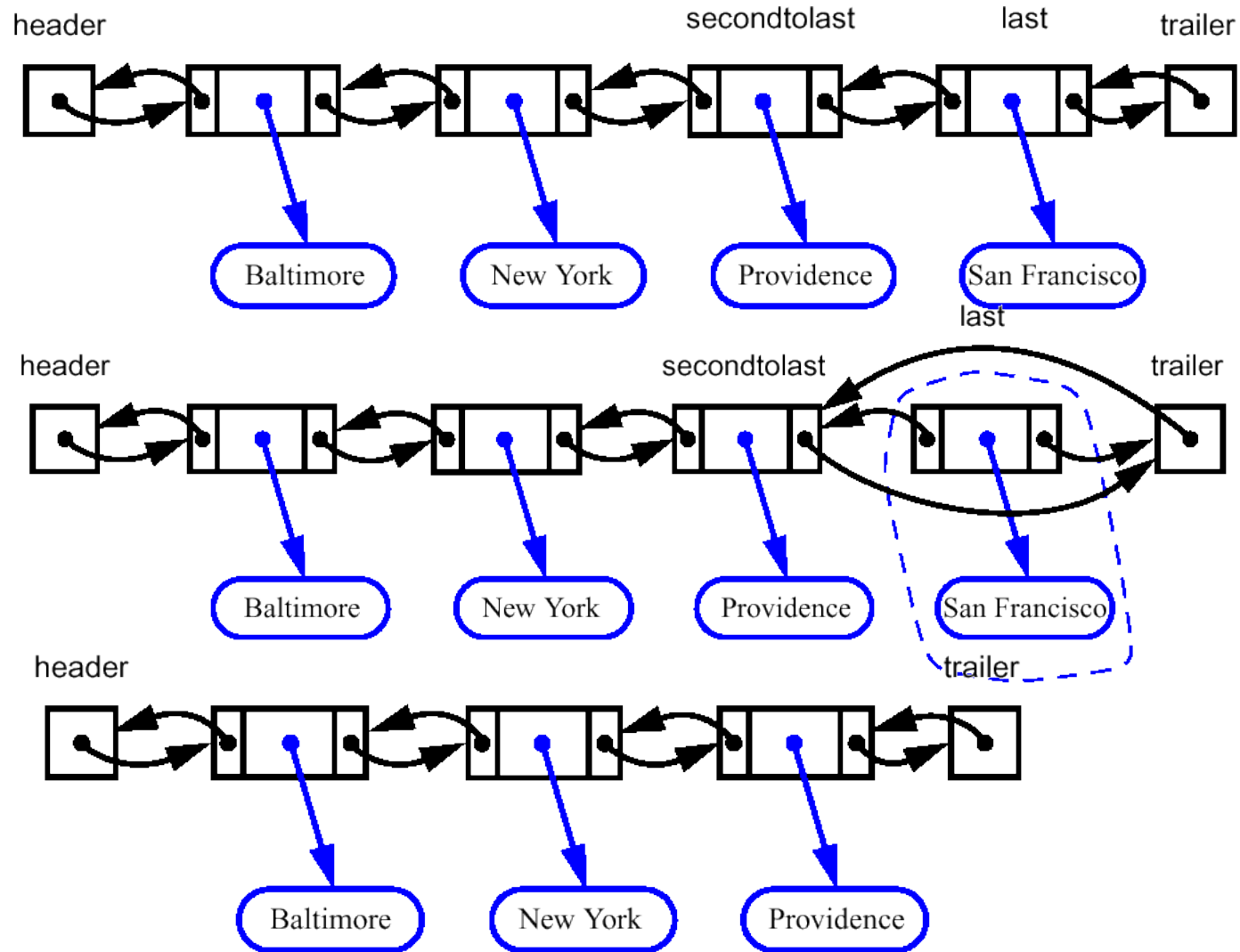

DSA, Chapter 5: Overview

- Dynamic Data Structures
 - Records, Pointers
 - Lists
- **Abstract Data Types**
 - Stack, Queue
 - Ordered Lists
 - Priority Queue

Abstract Data Types (ADTs)

An *ADT* is a mathematically specified entity that defines a set of its *instances* with:

- an *interface* – a collection of signatures of operations that can be invoked on an instance.
- a set of *conditions* (*preconditions* and *post-conditions*), possibly formulated as axioms, that define the *semantics* of the operations (i.e., *what* the operations do to instances of the ADT, but *not how*)

Examples of ADTs

We discuss a number of popular ADTs:

- Stacks
- Queues
- Priority Queues
- Ordered Lists
- Dictionaries (realized by Trees, next chapter)

They illustrate the use of lists and arrays

Why ADTs?

- ADTs allow one to break tasks into pieces that can be worked on independently – without compromising correctness.
 - They serve as *specifications of requirements* for the building blocks of solutions to algorithmic problems
- ADTs encapsulate *data structures* and algorithms that *implement* them.

Why ADTs?/2

- ADTs provide a language to talk on a higher level of abstraction
- ADTs allow one to separate *the check of correctness* and the *performance analysis*:
 1. Design the algorithm using an ADT
 2. Count how often different ADT operations are used
 3. Choose suitable implementations of ADT operations

ADT = Instance variables + procedures
(Class = Instance variables + methods)

DSA, Chapter 5: Overview

- Dynamic Data Structures
 - Records, Pointers
 - Lists
- Abstract Data Types
 - **Stack, Queue**
 - Ordered Lists
 - Priority Queue

Stacks

- In a stack, insertions and deletions follow the **last-in-first-out** (LIFO) principle.
- Thus, the element that has been in the queue for the shortest time is processed first
 - Example: OS stack, ...
- Solution: Elements are **inserted at the beginning** (push) and **removed from the beginning** (pop)

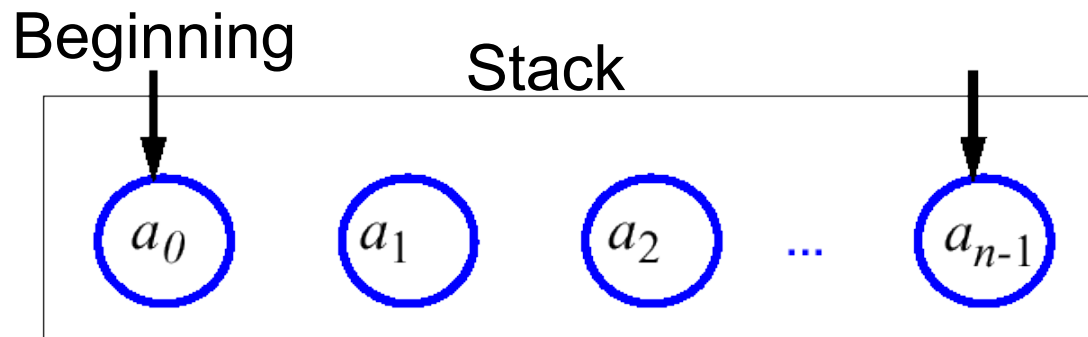

Stacks/2

We assume

- there is a *class Element*
- we want to store objects of *type Element* in our stacks

We require that stacks support the operations:

- *construction* of a stack
(possibly with a parameter for the maximal size)
- checking whether a stack is *empty*
- asking for the *current size* of the stack
- *pushing* an element onto the stack
- *popping* an element from the stack

Stacks/3

Appropriate data structure:

- Linked list, one head: good
- Array: fastest, limited in size
- Doubly linked list: unnecessary

An Array Implementation

- Create a stack using an array
- A maximum size N is specified
- The stack consists of an N -element array S and an integer variable *count*:
 - *count*: index of the front element (head)
 - *count* represents the position where to insert next element, and the number of elements in the stack

Array Implementation of Stacks

```
class Stack{
    int maxSize, count;
    Element[] S;

    Stack(int maxSize){
        this.maxSize = maxSize;
        S = new Element[maxSize];
        count = 0; }

    int size(){...}

    boolean isEmpty(){...}

    void push(Element x){ ... }

    Element pop(){ ... }

}
```

Java-style
implementation
of stacks

Array Implementation of Stacks/2

```
int size()  
    return count
```

```
boolean isEmpty()  
    return (count == 0)
```

```
Element pop()  
    if isEmpty() then Error  
    x = S[count-1]  
    count--;  
    return x
```

```
void push(Element x)  
    if count==maxSize then Error;  
    S[count] = x;  
    count++;
```

Java-style
implementation
of stacks:
arrays start at
position 0

A Linked-list Implementation

- A list of integers:

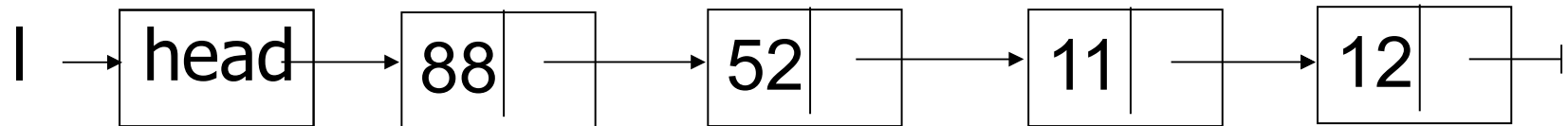

- Insert from the top of the list

```
void push(Element x) :  
  
node p = new node() ;  
p.val = x ;  
p.next = head ;  
head = p ;
```

- Constant-time operation!

A Linked-list Implementation/2

- A list of integers:

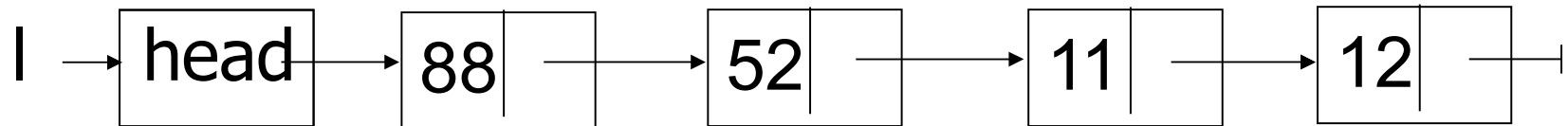

- Extract from the top of the list

```
Element pop() :
```

```
x = head.val;  
head = head.next;  
return x;
```

- Constant-time operation!

Queues

- In a queue insertions and deletions follow the **first-in-first-out** (FIFO) principle
- Thus, the element that has been in the queue for the longest time is processed first
 - Example: Printer queue, ...
- Solution: Elements are **inserted at the end** (enqueue) and **removed from the beginning** (dequeue).

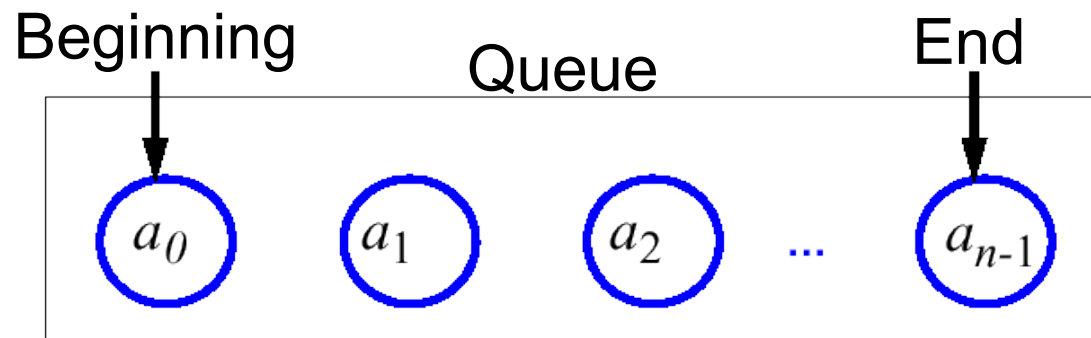

Queues/2

We assume

- there is a *class Element*
- we want to store objects of *type Element* in our queues

We require that queues support the operations:

- *construction* of a queue
(possibly with a parameter for the maximal size)
- checking whether a queue is *empty*
- asking for the *current size* of the queue
- *enqueueing* an element into the queue
- *dequeueing* an element from the queue

Queues/3

Appropriate data structure:

- Linked list, head: inefficient insertions
- Linked list, head/tail: good
- Array: fastest, limited in size
- Doubly linked list: unnecessary

An Array Implementation

- Create a queue using an array in a circular fashion
- A maximum size $maxSize$ is specified
- The queue consists of an N -element array Q and two integer variables:
 - f , index of the **front** element (head, for dequeue)
 - r , index of the element after the last one (**rear**, for enqueueing)



An Array Implementation/2

“Wrapped around” configuration:

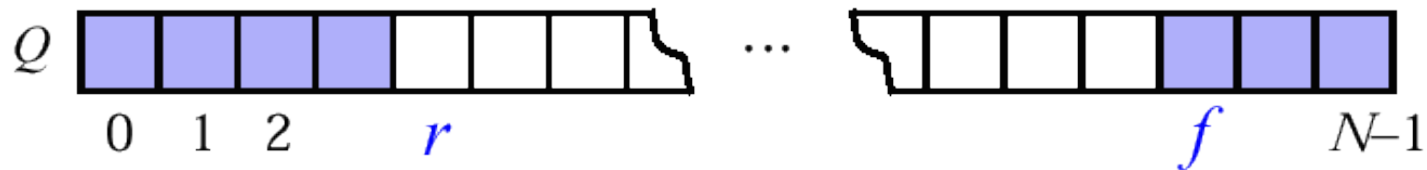

What does “ $f == r$ ” mean?

An Array Implementation/3

In the array implementation of **stacks**

- we needed an array of size N
to realize a stack of maximal size N
- we could model the empty stack with “**count == 0**”

Let's model a queue with an array of size N and “pointers” f , r :

- if f is **fixed**, then r can have N different **values**,
one of them models “the queue is empty”
- hence, we can only store $N-1$ **elements**,
if we implement our queue with an array of length N

Array Implementation of Queues/3

```
class Queue{
    int N, f, r;
    Element[] Q;

    Queue(int maxSize){
        this.N = maxSize + 1;
        Q = new Element[N];
        f = 0; r = 0;}

    int size(){...}

    boolean isEmpty(){...}

    void enqueue(Element x){ ... }

    Element dequeue(){ ... }

}
```

Java-style
implementation
of queues

An Array Implementation of Queues/4

```
int size()  
    return (r-f+N) mod N
```

```
boolean isEmpty()  
    return size() == 0
```

```
Element dequeue()  
    if isEmpty() then Error  
    x = Q[f]  
    f = (f+1) mod N  
    return x
```

```
void enqueue(Element x)  
    if size() == N-1 then Error  
    Q[r] = x  
    r = (r+1) mod N
```

We assume
arrays
as in Java,
with indexes
from 0 to N-1

A Linked-list Implementation

Use linked-list with head and tail

Insert in tail, extract from head

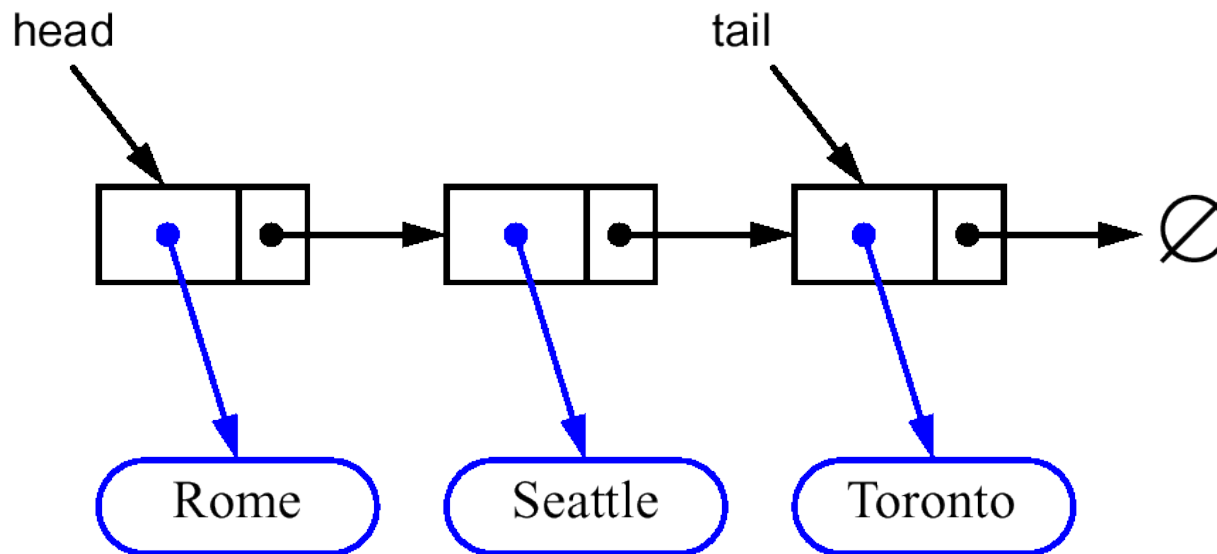

A Linked-list implementation/2

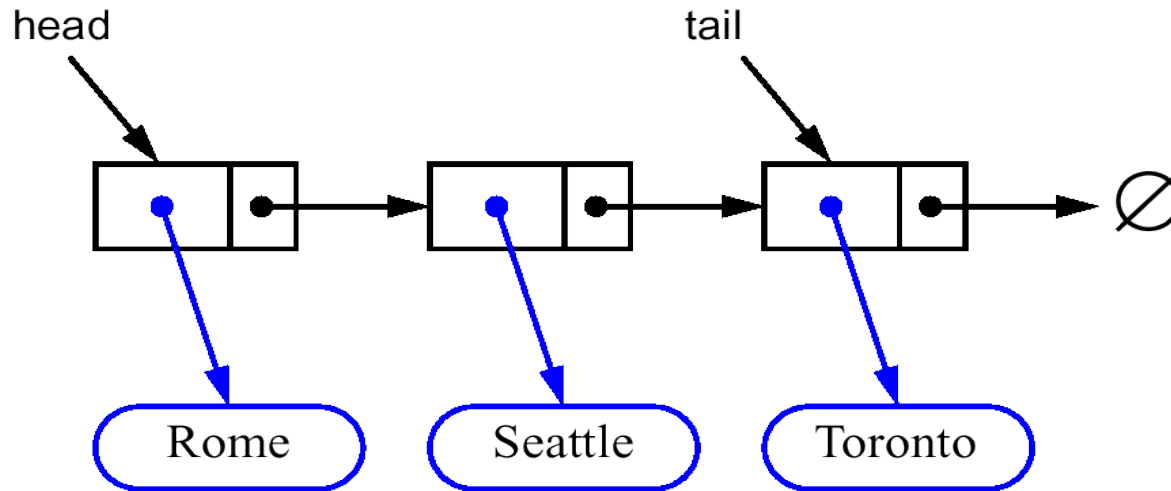

Insert at the end of the list: $O(1)$

```
void enqueue(Element x) :  
node p = new node();  
p.info = x; p.next = null;  
tail.next=p;  
tail=tail.next;
```

A Linked-list Implementation/3

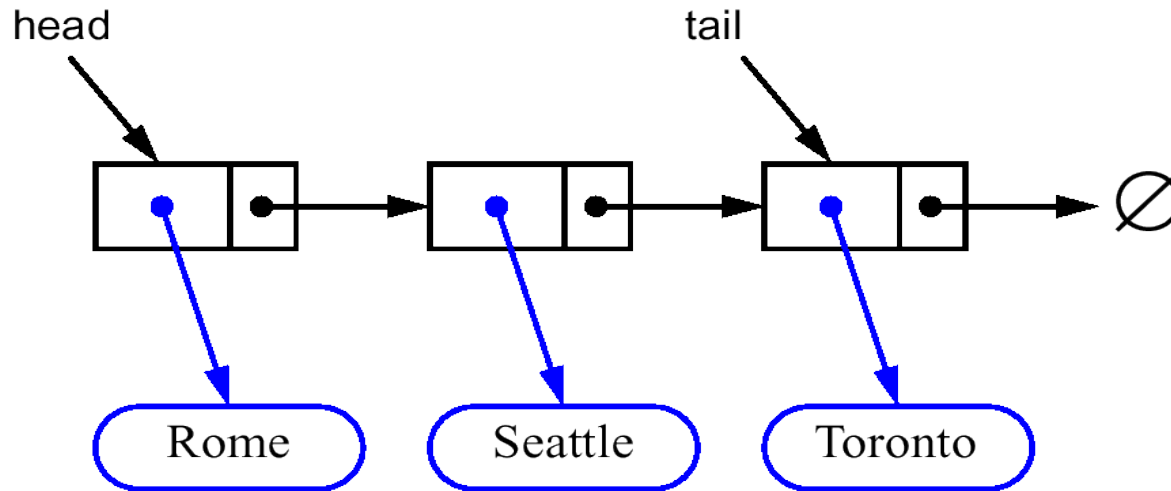

Insert at the end of the list: $O(1)$

```
Element dequeue():  
x = head.info;  
head = head.next;  
return x;
```

Suggested Exercises

- Implement stack and queue as arrays
- Implement stack and queue as linked lists, with the same interface as the array implementation

Suggested Exercises/2

- Suppose a queue of integers is implemented with an array of 8 elements: draw the outputs and status of such array after the following operations:
 - enqueue 2, 4, 3, 1, 7, 6, 9
 - dequeue 3 times
 - enqueue 2, 3, 4

Can we enqueue any more element?

- Try the same with a stack
- Try similar examples (also with a stack)

DSA, Chapter 5: Overview

- Dynamic Data Structures
 - Records, Pointers
 - Lists
- Abstract Data Types
 - Stack, Queue
 - **Ordered Lists**
 - Priority Queue

Ordered List

- In an ordered list Elements are ordered according to a key, which we assume to be an integer
- Example functions on ordered list:
 - `isEmpty()`
 - `int maxKey(), int minKey()`
 - `Element find(int key)`
 - `Element floorEntry(int key)`
 - `Element ceilingEntry(int key)`
 - `insert(int key, Element x)`
 - `print()`

Ordered List/2

- Declaration of an ordered list similar to unordered list
- Some operations (search, and hence insert and delete) are slightly different

```
class Node{
    int key; value Element;
    Node next;
}
```

```
class OList{
    Node head;
}
```

Ordered List/3

- Insertion into an ordered list (Java):

```
void insert(int i, Element x) {
    Node q = new Node();
    q.key = i; q.element = x; q.next = NULL;
    Node p;

    if (head == NULL || head.key > i) {
        q.next = head;
        head = q;
    } else {
        ...
    }
}
```

Ordered List/4

Insertion into an ordered list (Java):

```
void insert(int i, Element x) {  
    ...  
} else {  
    p = head;  
    while (p.next != NULL && p.next.key < i)  
        p = p.next;  
    q.next = p.next;  
    p.next = q;  
}  
}
```

Ordered List

Cost of operations:

- Insertion: $O(n)$
- Check isEmpty: $O(1)$
- Search: $O(n)$
- Delete: $O(n)$
- Print: $O(n)$

Suggested Exercises

- Implement an ordered list with the following functionalities: isEmpty, insert, search, delete, print
- Implement also deleteAllOccurrences
- As before, with a recursive version of: insert, search, delete, print
 - are recursive versions simpler?
- Implement an efficient version of print which prints the list in reverse order

DSA, Chapter 5: Overview

- Dynamic Data Structures
 - Records, Pointers
 - Lists
- Abstract Data Types
 - Stack, Queue
 - Ordered Lists
 - **Priority Queue**

Priority Queues

- A priority queue (PQ) is an *ADT* for maintaining a set S of elements, each with an associated value called *key*
- A PQ supports the following operations
 - **Insert**(S,x) insert element x in set S ($S := S \cup \{x\}$)
 - **ExtractMax**(S) returns and removes the element of S with the largest key
- One way of implementing it: a heap

Array Implementation of Priority Queues

```
class PQueue{
    int maxSize, size;
    int[] A;

    PQueue(int maxSize){
        this.maxsize = maxSize;
        A = new int[N];
        size = 0;}

    int size(){...}

    boolean isEmpty(){...}

    void insert(int key){ ... }

    int extractMax(){ ... }

}
```

Java-style implementation of priority queue of integers, details to be worked out as assignment

Suggested Exercises

- Implement a priority queue
- Consider the PQ of previous slides. Draw the status of the PQ after each of the following operations:
 - Insert 17,18,18,19
 - Extract four numbers
 - Insert again 17,18,18,19
- Build a PQ from scratch, adding and inserting elements at will, and draw the status of the PQ after each operation

Summary

- Records, Pointers
- Dynamic Data Structures
 - Lists (head, head/tail, doubly linked)
- Abstract Data Types
 - Type + Functions
 - Stack, Queue
 - Ordered Lists
 - Priority Queues

Next Chapter

- Binary Search Trees
- Red-Black Trees