

# Description Logics

## Structural Description Logics

*Enrico Franconi*

`franconi@cs.man.ac.uk`

`http://www.cs.man.ac.uk/~franconi`

Department of Computer Science, University of Manchester

# Description Logics

- A logical reconstruction and *unifying* formalism for the representation tools
  - Frame-based systems
  - Semantic Networks
  - Object-Oriented representations
  - Semantic data models
  - Ontology languages
  - . . .
- A *structured* fragment of predicate logic
- Provide theories and systems for *expressing* structured information and for *accessing* and *reasoning* with it in a principled way.

# Applications

Description logics based systems are currently in use in many applications.

- Configuration
- Conceptual Modeling
- Query Optimization and View Maintenance
- Natural Language Semantics
- I3 (Intelligent Integration of Information)
- Information Access and Intelligent Interfaces
- Terminologies and Ontologies
- Software Management
- Planning

# A formalism

- Description Logics formalize many *Object-Oriented* representation approaches.
- As such, their purpose is to disambiguate many imprecise representations.

# Frames or Objects

- Identifier
- Class
- Instance
- Slot (attribute)
  - Value
    - Identifier
    - Default
  - Value restriction
    - Type
    - Concrete Domain
    - Cardinality
    - Encapsulated method

# Ambiguities: classes and instances

Person : AGE : Number,  
SEX : *M*, *F*,  
HEIGHT : Number,  
WIFE : Person.

*john* : AGE : 29,  
SEX : *M*,  
HEIGHT : 76,  
WIFE : *mary*.

# Ambiguities: incomplete information

29'er : AGE : 29,  
SEX : *M*,  
HEIGHT : Number,  
WIFE : Person.

*john* : AGE : 29,  
SEX : *M*,  
HEIGHT : Number,  
WIFE : Person.

# Ambiguities: is-a

Sub-class:

```
Person : AGE : Number,  
        SEX : M, F,  
        HEIGHT : Number,  
        WIFE : Person.
```

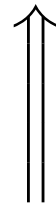

```
Male : AGE : Number,  
      SEX : M,  
      HEIGHT : Number,  
      WIFE : Female.
```



# Ambiguities: is-a

Instance-of:

Male : AGE : Number,  
SEX : *M*,  
HEIGHT : Number,  
WIFE : Female.

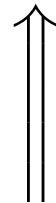

*john* : AGE : 35,  
SEX : *M*,  
HEIGHT : 76,  
WIFE : *mary*.

# Ambiguities: is-a

Instance-of:

*29'er* : AGE : 29,  
SEX : *M*,  
HEIGHT : Number,  
WIFE : Person.

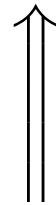

*john* : AGE : 29,  
SEX : *M*,  
HEIGHT : Number,  
WIFE : Person.

# Ambiguities: relations

Implicit relation:

*john* : AGE : 35,  
SEX : *M*,  
HEIGHT : 76,  
WIFE : *mary*.

*mary* : AGE : 32,  
SEX : *F*,  
HEIGHT : 59,  
HUSBAND : *john*.

# Ambiguities: relations

Explicit relation:

*john* : AGE : 35,  
SEX : *M*,  
HEIGHT : 76.

*mary* : AGE : 32,  
SEX : *F*,  
HEIGHT : 59.

*m-j-family* : WIFE : *mary*,  
HUSBAND : *john*.

# Ambiguities: relations

Special relation:

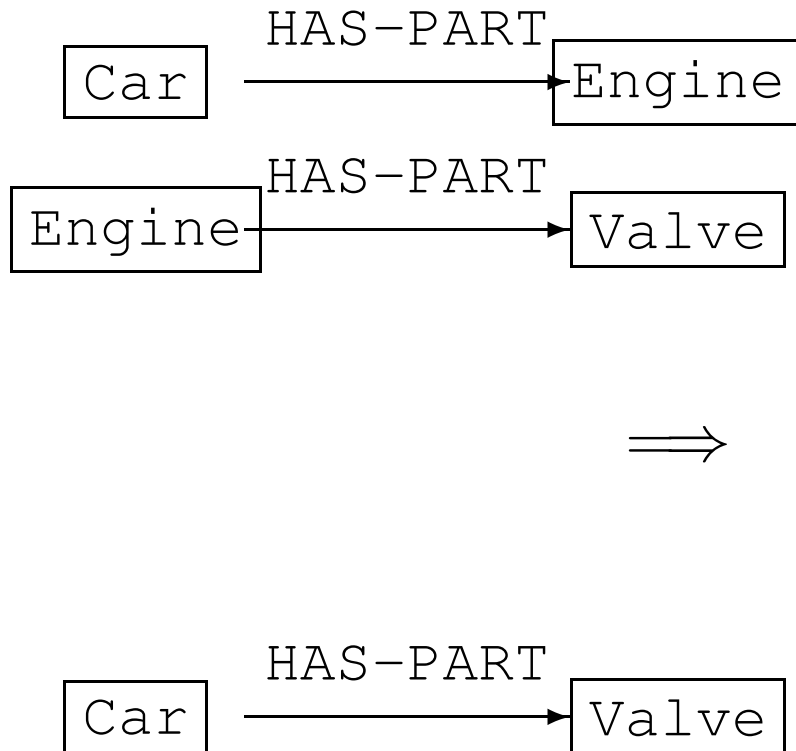

# Ambiguities: relations

Normal relation:

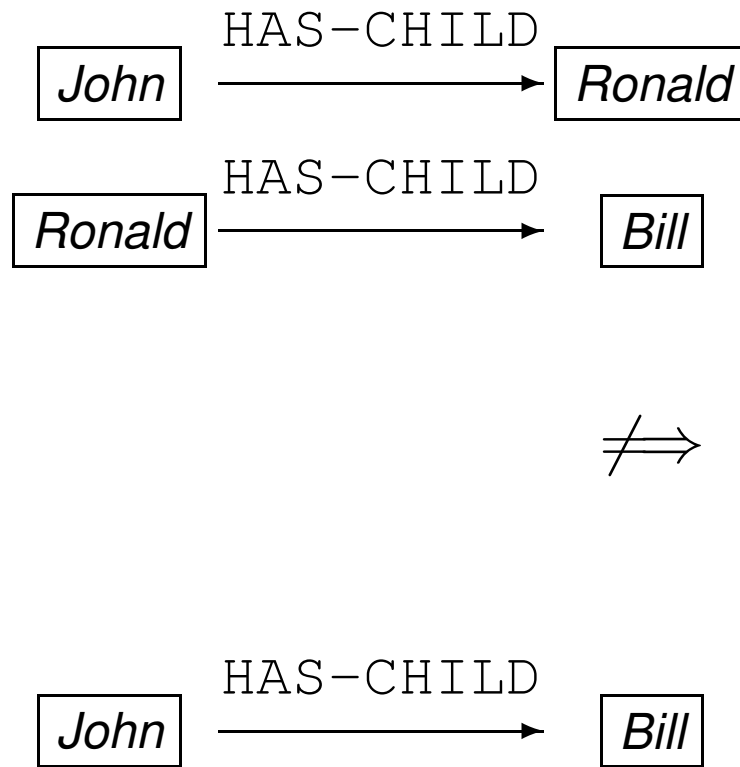

# Ambiguities: default

The *Nixon* diamond:

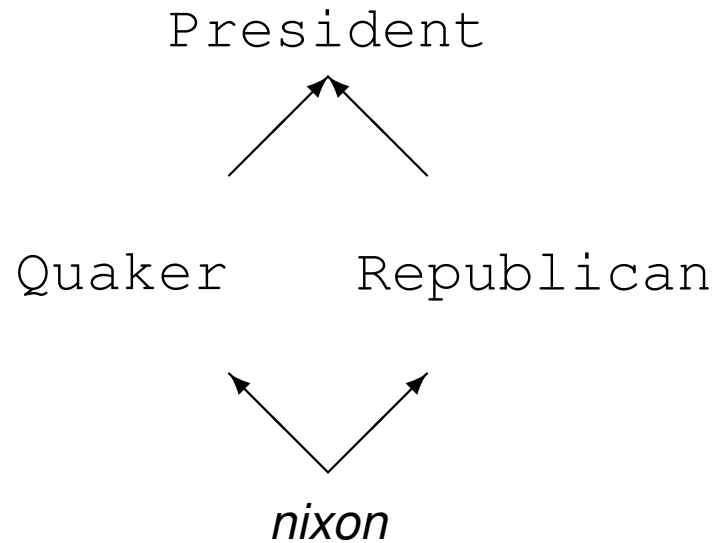

Quakers are pacifist, Republicans are not pacifist.

⇒ Is Nixon pacifist or not pacifist?

# Ambiguities: quantification

What is the exact meaning of:

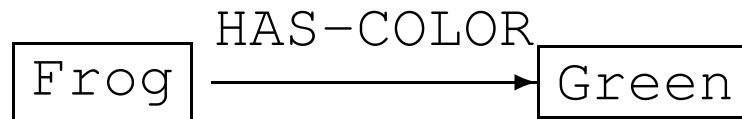



# Ambiguities: quantification

What is the exact meaning of:

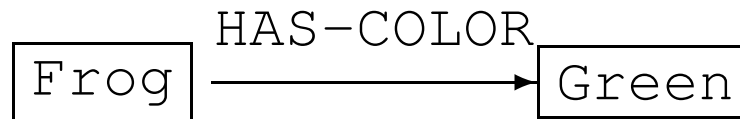

- Every frog is just green

# Ambiguities: quantification

What is the exact meaning of:

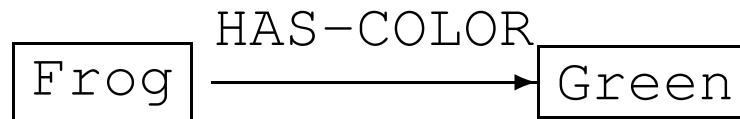

- Every frog is just green
- Every frog is also green

# Ambiguities: quantification

What is the exact meaning of:

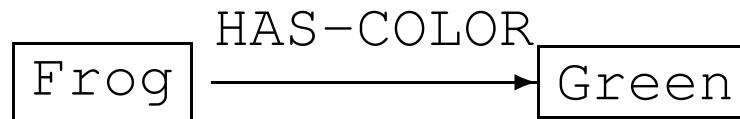

- Every frog is just green
- Every frog is also green
- Every frog is of some green

# Ambiguities: quantification

What is the exact meaning of:

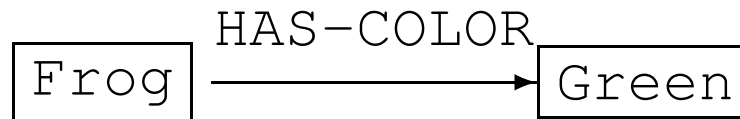

- Every frog is just green
- Every frog is also green
- Every frog is of some green
- There is a frog, which is just green
- ...

# Ambiguities: quantification

What is the exact meaning of:

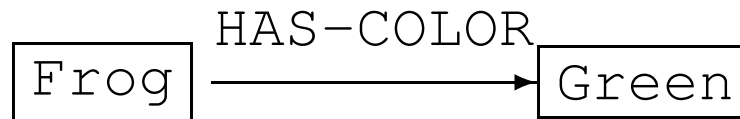

- Every frog is just green
- Every frog is also green
- Every frog is of some green
- There is a frog, which is just green
- ...
- Frogs are typically green, but there may be exceptions

# False friends

- The meaning of object-oriented representations is logically very ambiguous.
- The appeal of the graphical nature of object-oriented representation tools has led to forms of reasoning that do not fall into standard logical categories, and are not yet very well understood.
- It is unfortunately much easier to develop some algorithm that appears to reason over structures of a certain kind, than to *justify* its reasoning by explaining what the structures are saying about the domain.

# A structured logic

- Any (basic) Description Logic is a fragment of FOL.
- The representation is at the *predicate level*: no variables are present in the formalism.
- A Description Logic theory is divided in two parts:
  - the definition of predicates (*TBox*)
  - the assertion over constants (*ABox*)
- Any (basic) Description Logic is a subset of  $\mathcal{L}_3$ , i.e. the function-free FOL using only at most *three* variable names.

# Why not FOL

If FOL is directly used without additional restrictions then

- the structure of the knowledge is destroyed, and it can not be exploited for driving the inference;
- the expressive power is too high for obtaining decidable and efficient inference problems;
- the inference power may be too low for expressing interesting, but still decidable theories.



# Structured Inheritance Networks: KL-ONE

- Structured Descriptions
  - corresponding to the complex relational structure of objects,
  - built using a restricted set of epistemologically adequate constructs
- distinction between conceptual (*terminological*) and instance (*assertional*) knowledge;
- central role of automatic classification for determining the subsumption – i.e., universal implication – lattice;
- strict reasoning, no defaults.

# Types of the TBox Language

- **Concepts** – denote *entities*  
(unary predicates, classes)

*Example:* Student, Married

$\{x \mid \text{Student}(x)\},$

$\{x \mid \text{Married}(x)\}$

- **Roles**– denote *properties*  
(binary predicates, relations)

*Example:* FRIEND, LOVES

$\{\langle x, y \rangle \mid \text{FRIEND}(x, y)\},$

$\{\langle x, y \rangle \mid \text{LOVES}(x, y)\}$

# Concept Expressions

Description Logics organize the information in classes – *concepts* – gathering homogeneous data, according to the relevant common properties among a collection of instances.

*Example:*

Student  $\sqcap$   $\exists$ FRIEND.Married

$$\{x \mid \text{Student}(x) \wedge \exists y. \text{FRIEND}(x, y) \wedge \text{Married}(y)\}$$

## A note on $\lambda$ 's

In general,  $\lambda$  is an explicit way of forming *names* of functions:

$\boxed{\lambda x. f(x)}$  is the function that, given input  $x$ , returns the value  $f(x)$

The  $\lambda$ -conversion rule says that:

$$(\lambda x. f(x))(a) = f(a)$$

Thus,  $\boxed{\lambda x. (x^2 + 3x - 1)}$  is the function that applied to 2 gives 9:

$$(\lambda x. (x^2 + 3x - 1))(2) = 9$$

We can give a name to this function, so that:

$$\begin{aligned} f_{231} &\doteq \lambda x. (x^2 + 3x - 1) \\ f_{231}(2) &= 9 \end{aligned}$$

## $\lambda$ to define predicates

Predicates are special case of functions: they are *truth* functions. So, if we think of a formula  $P(x)$  as denoting a truth value which may vary as the value of  $x$  varies, we have:

$\lambda x. P(x)$  denotes a function from domain individuals to truth values.

In this way, as we have learned from FOL,  $P$  denotes exactly the set of individuals for which it is true. So,  $P(a)$  means that the individual  $a$  makes the predicate  $P$  true, or, in other words, that  $a$  is in the extension of  $P$ .

For example, we can write for the *unary* predicate `Person`:

$$\text{Person} \doteq \lambda x. \text{Person}(x)$$

which is equivalent to say that `Person` denotes the *set* of persons:

$$\text{Person} \rightsquigarrow \{x \mid \text{Person}(x)\}$$

$$\text{Person}^{\mathcal{I}} = \{x \mid \text{Person}(x)\}$$

$$\text{Person}(\text{john}) \text{ IFF } \text{john}^{\mathcal{I}} \in \text{Person}^{\mathcal{I}}$$

In the same way for the *binary* predicate `FRIEND`:

$$\text{FRIEND} \doteq \lambda x, y. \text{FRIEND}(x, y)$$

$$\text{FRIEND}^{\mathcal{I}} = \{\langle x, y \rangle \mid \text{FRIEND}(x, y)\}$$

The functions we are defining with the  $\lambda$  operator may be parametric:

$$\text{Student} \sqcap \text{Worker} = \lambda x. (\text{Student}(x) \wedge \text{Worker}(x))$$

$$(\text{Student} \sqcap \text{Worker})^{\mathcal{I}} = \{x \mid (\text{Student}(x) \wedge \text{Worker}(x))\}$$

$$(\text{Student} \sqcap \text{Worker})^{\mathcal{I}} = \text{Student}^{\mathcal{I}} \cap \text{Worker}^{\mathcal{I}}$$

*(Verify as exercise)*

# Concept Expressions

$$(\text{Student} \sqcap \exists \text{FRIEND.Married})^{\mathcal{I}}$$
$$=$$
$$(\text{Student})^{\mathcal{I}} \cap (\exists \text{FRIEND.Married})^{\mathcal{I}}$$
$$=$$
$$\{x \mid \text{Student}(x)\} \cap$$
$$\{x \mid \exists y. \text{FRIEND}(x, y) \wedge \text{Married}(y)\}$$
$$=$$
$$\{x \mid \text{Student}(x) \wedge$$
$$\exists y. \text{FRIEND}(x, y) \wedge \text{Married}(y)\}$$



# Objects: classes

Student

|           |          |
|-----------|----------|
| Person    |          |
| name:     | [String] |
| address:  | [String] |
| enrolled: | [Course] |

$$\{x \mid \text{Student}(x)\} = \{x \mid \text{Person}(x) \wedge$$
$$(\exists y. \text{NAME}(x, y) \wedge \text{String}(y)) \wedge$$
$$(\exists z. \text{ADDRESS}(x, z) \wedge \text{String}(z)) \wedge$$
$$(\exists w. \text{ENROLLED}(x, w) \wedge \text{Course}(w)) \}$$

Student  $\doteq$  Person  $\sqcap$

$\exists$ NAME.String  $\sqcap$

$\exists$ ADDRESS.String  $\sqcap$

$\exists$ ENROLLED.Course

# Objects: instances

|             |                   |
|-------------|-------------------|
| s1: Student |                   |
| name:       | “John”            |
| address:    | “Abbey Road. . .” |
| enrolled:   | cs415             |

$\text{Student}(s1) \wedge$

$\text{NAME}(s1, \text{“john”}) \wedge \text{String}(\text{“john”}) \wedge$

$\text{ADDRESS}(s1, \text{“abbey-road”}) \wedge \text{String}(\text{“abbey-road”}) \wedge$

$\text{ENROLLED}(s1, \text{cs415}) \wedge \text{Course}(\text{cs415})$

# Semantic Networks

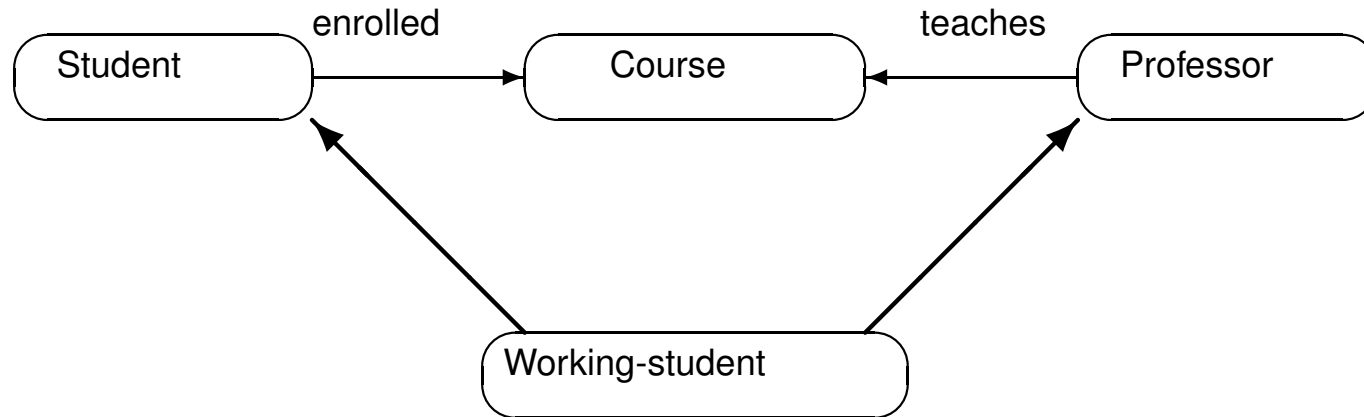

$\forall x. \text{Student}(x) \rightarrow \exists y. \text{ENROLLED}(x, y) \wedge \text{Course}(y)$        $\text{Student} \sqsubseteq \exists \text{ENROLLED}.\text{Course}$   
 $\forall x. \text{Professor}(x) \rightarrow \exists y. \text{TEACHES}(x, y) \wedge \text{Course}(y)$        $\text{Professor} \sqsubseteq \exists \text{TEACHES}.\text{Course}$

$\forall x. \text{Working-student}(x) \rightarrow \text{Student}(x) \wedge \text{Professor}(x)$   
 $\text{Working-student} \sqsubseteq \text{Student}$   
 $\text{Working-student} \sqsubseteq \text{Professor}$

# Quantification

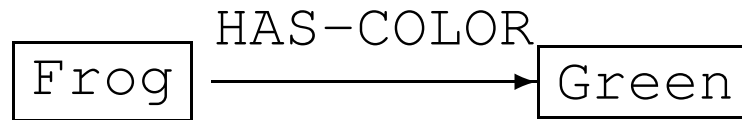

- $\text{Frog} \sqsubseteq \exists \text{HAS-COLOR.Green}$ :  
Every frog is also green
- $\text{Frog} \sqsubseteq \forall \text{HAS-COLOR.Green}$ :  
Every frog is just green
- $\text{Frog} \sqsubseteq \forall \text{HAS-COLOR.Green}$   
 $\text{Frog}(x), \text{HAS-COLOR}(x, y)$ :  
There is a frog, which is just green

# Quantification: existential

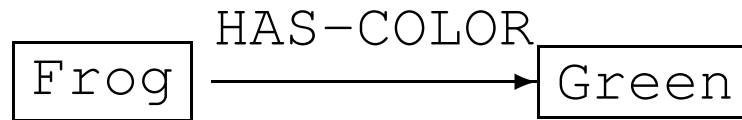

Every frog is also green

$\text{Frog} \sqsubseteq \exists \text{HAS-COLOR}.\text{Green}$

$\forall x. \text{Frog}(x) \rightarrow$

$\exists y. (\text{HAS-COLOR}(x, y) \wedge \text{Green}(y))$

*Exercise: is this a model?*

$\text{Frog}(\text{oscar}), \text{Green}(\text{green}),$

$\text{HAS-COLOR}(\text{oscar}, \text{green}),$

$\text{Red}(\text{red}),$

$\text{HAS-COLOR}(\text{oscar}, \text{red}).$

# Quantification: universal

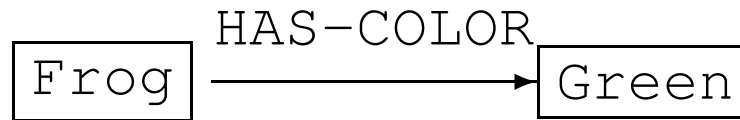

Every frog is only green

$\text{Frog} \sqsubseteq \forall \text{HAS-COLOR. Green}$

$\forall x. \text{Frog}(x) \rightarrow$

$\forall y. (\text{HAS-COLOR}(x, y) \rightarrow \text{Green}(y))$

*Exercise: is this a model?*

$\text{Frog}(\textit{oscar}), \text{Green}(\textit{green}),$

$\text{HAS-COLOR}(\textit{oscar}, \textit{green}),$

$\text{Red}(\textit{red}),$

$\text{HAS-COLOR}(\textit{oscar}, \textit{red}).$

*and this?*

$\text{Frog}(\textit{sing}),$

$\text{AGENT}(\textit{sing}, \textit{oscar}).$

# Analytic reasoning (intuition)

Person

*subsumes*

(Person **with every** male friend **is a** doctor)

*subsumes*

(Person **with every** friend **is a**

(Doctor **with a** specialty **is** surgery))

# Analytic reasoning (intuition)

Person

*subsumes*

(Person **with every** male friend **is a** doctor)

*subsumes*

(Person **with every** friend **is a**

(Doctor **with a** specialty **is** surgery))

(Person **with**  $\geq 2$  children)

*subsumes*

(Person **with**  $\geq 3$  male children)



# Analytic reasoning (intuition)

Person

*subsumes*

(Person **with every** male friend **is a** doctor)

*subsumes*

(Person **with every** friend **is a**

(Doctor **with a** specialty **is** surgery))

(Person **with**  $\geq 2$  children)

*subsumes*

(Person **with**  $\geq 3$  male children)

(Person **with**  $\geq 3$  young children)

*disjoint*

(Person **with**  $\leq 2$  children)